

Jøtul F 520 / Jøtul F 520 High Top

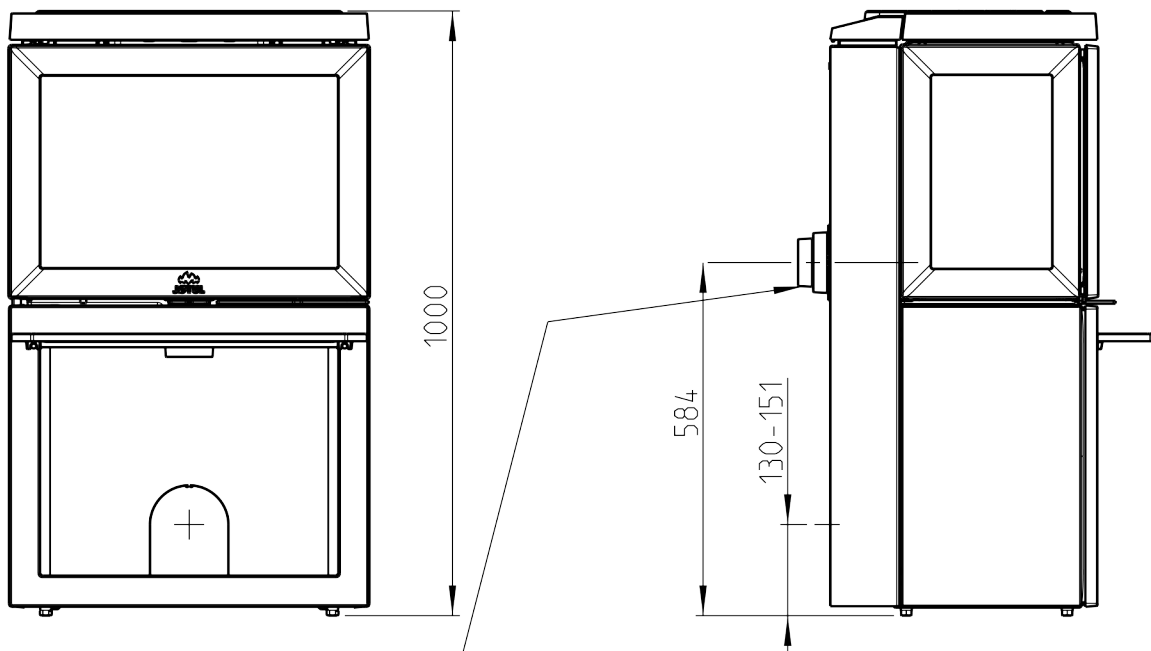

Hål i vägg för friskluftsanslutning
Ø 80 / Ø 100

Hål i golv för friskluftsanslutning
Ø 80 / Ø 100

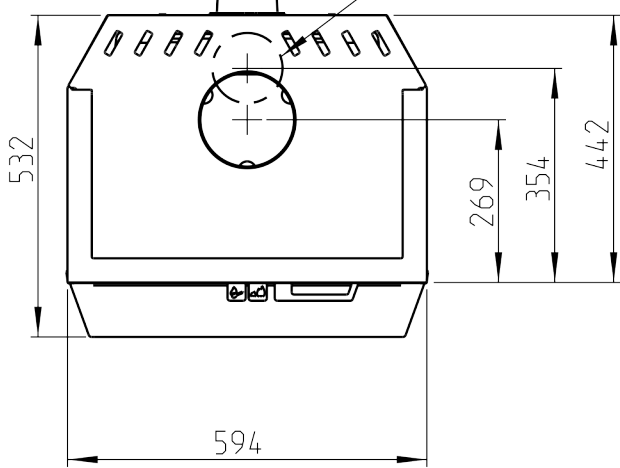

Minsta avstånd till möbler/brännbara material

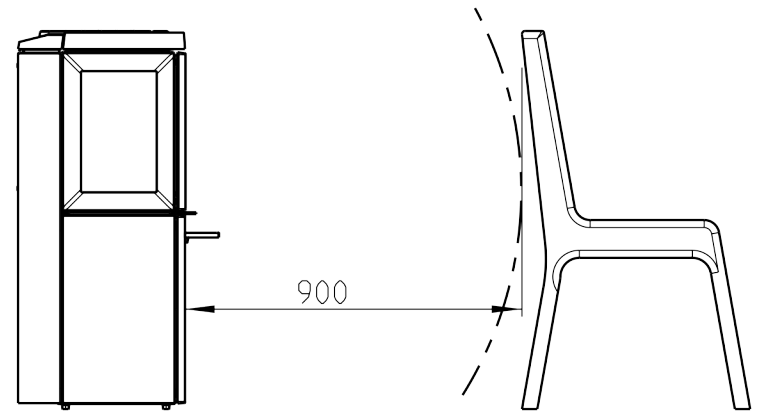

Minsta avstånd till tak

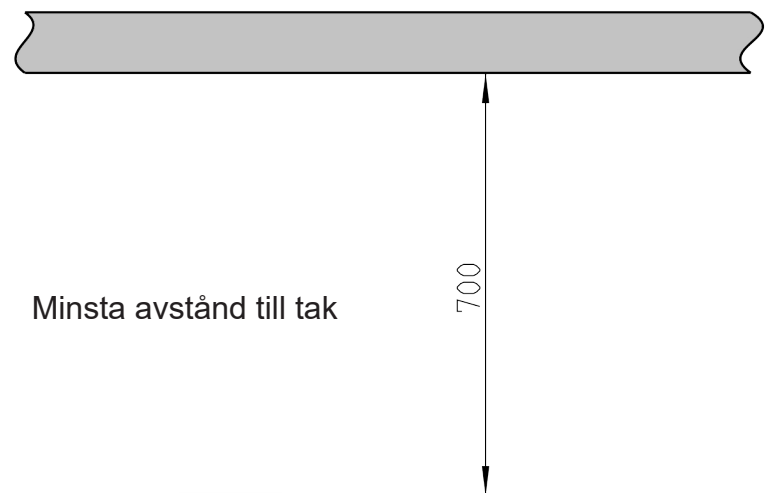

Uttag bak
Endast för High Top

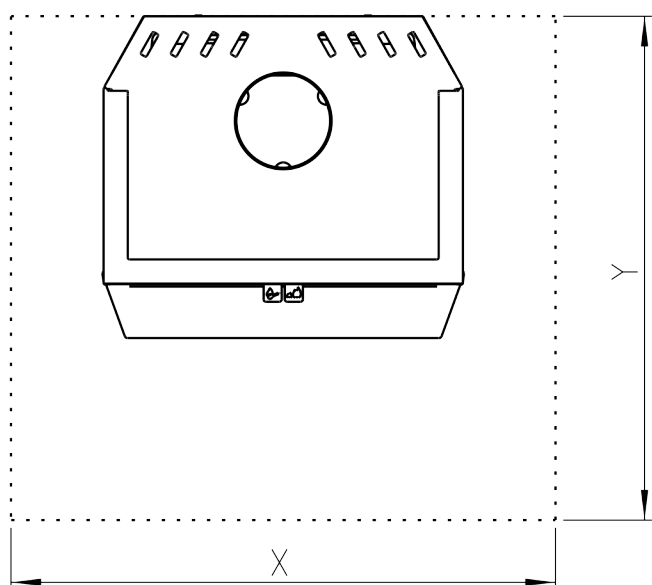
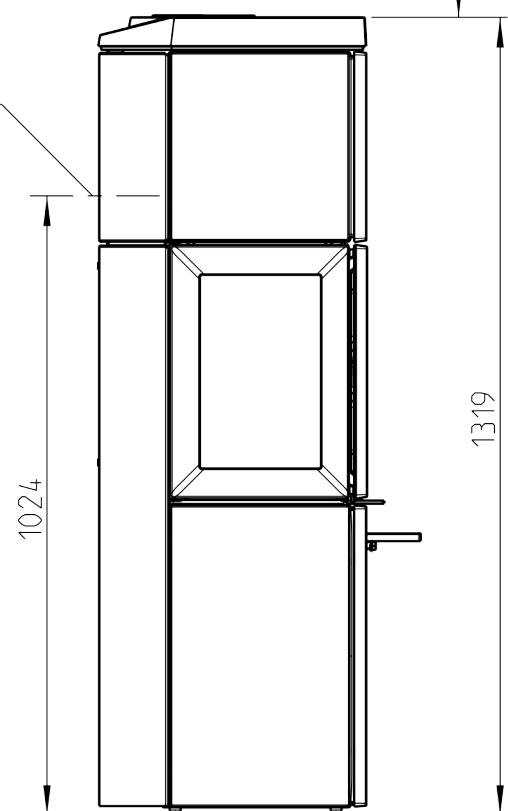

Minsta mått för eldstadsplan
X/Y = enligt nationella lagar och bestämmelser

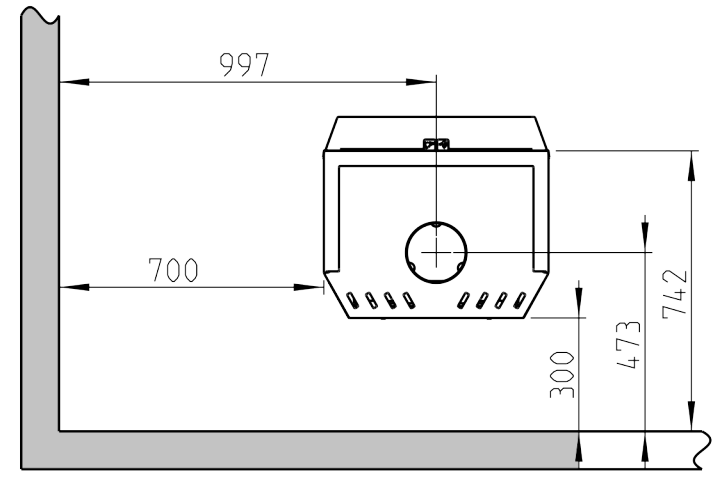
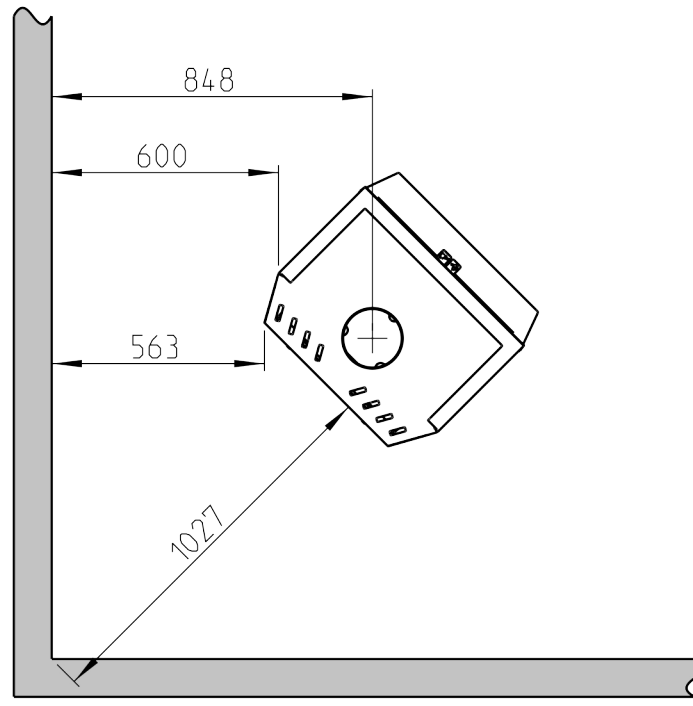
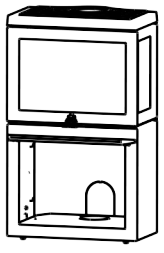

Med eftermonterad gjutjärnssida

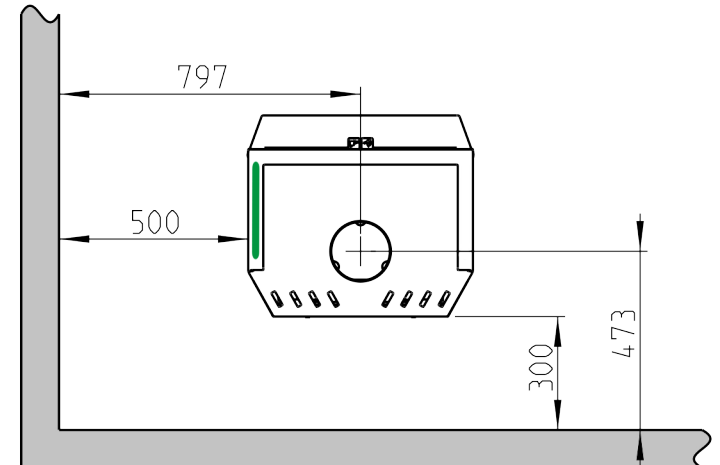
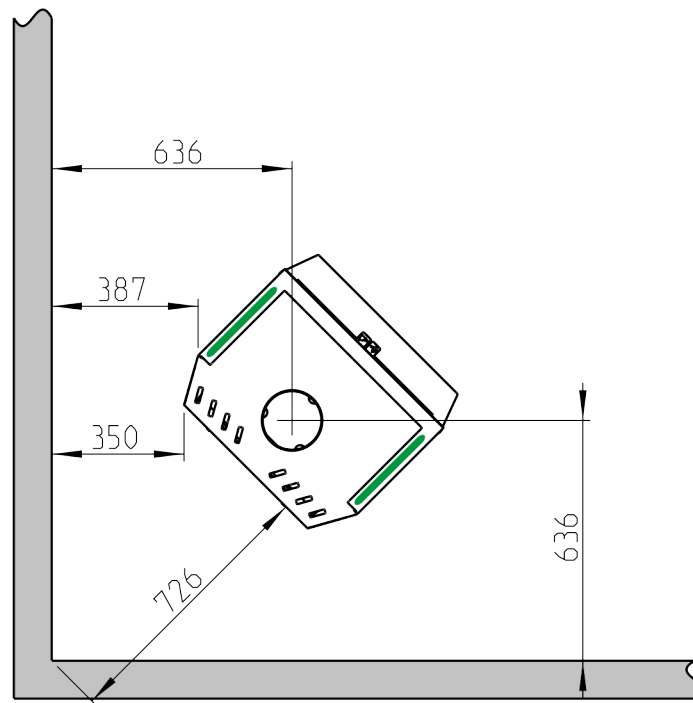
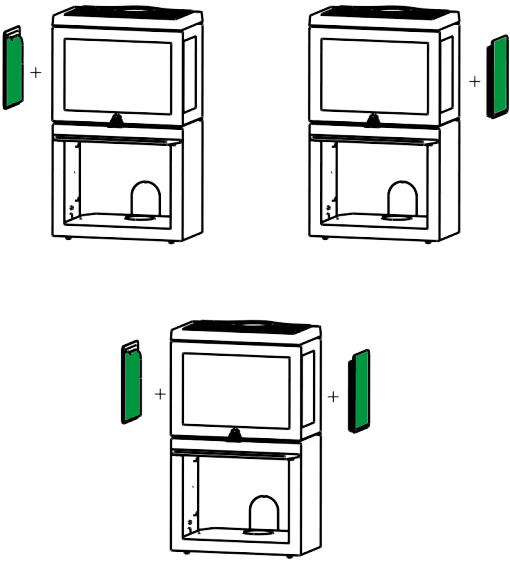

– Med eftermonterad gjutjärnssida och konvektionsset på sidan
– Med eftermonterat konvektionsset baktill

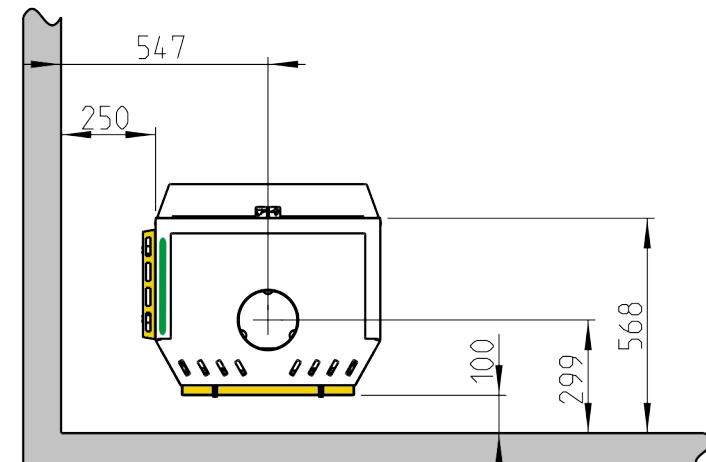
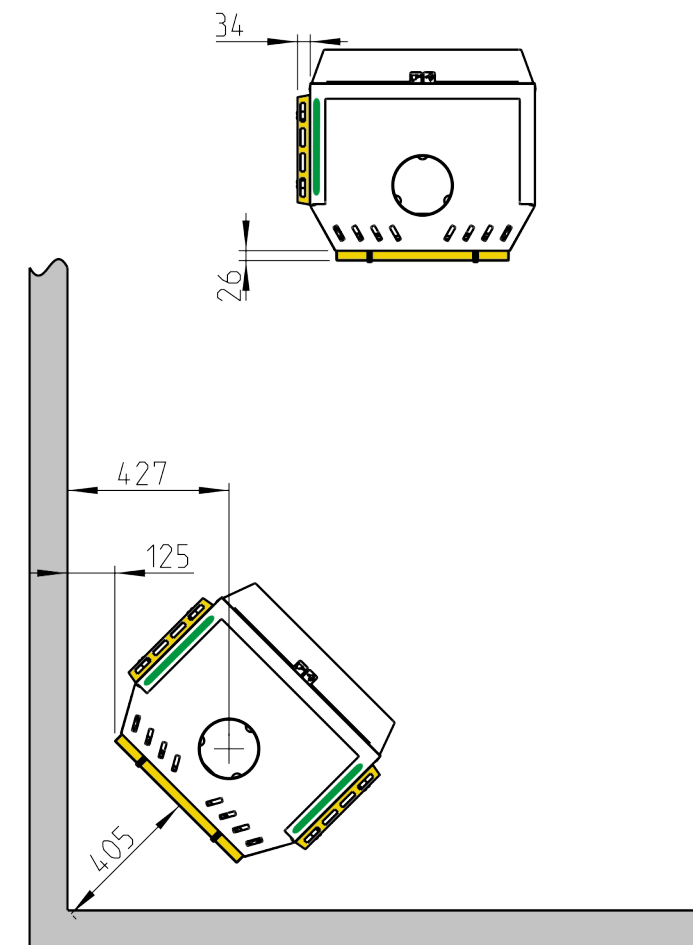
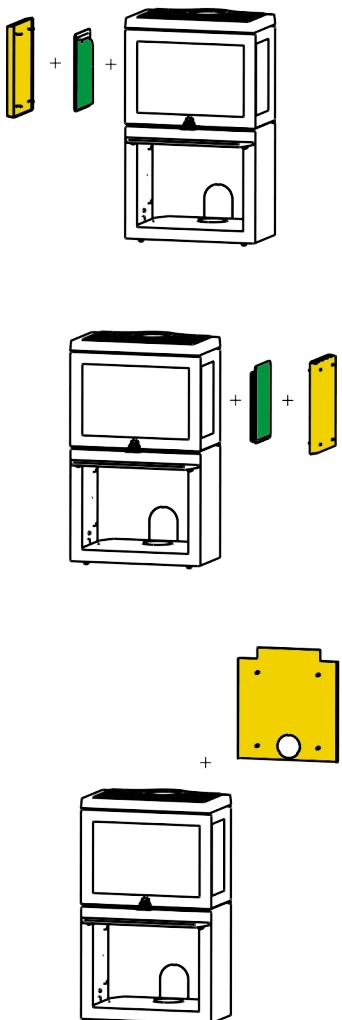

F 520 / F 520 High Top: Minsta avstånd till brännbar vägg skyddad av godkänd brandvägg

Halvisolererad skorsten/skärmat rökrör helt ned mot produkten

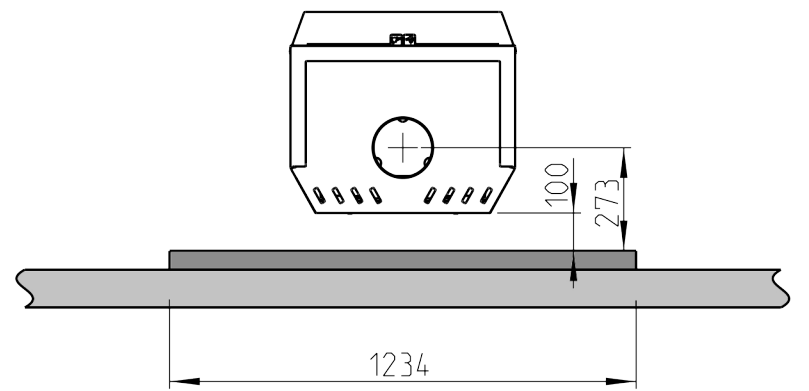
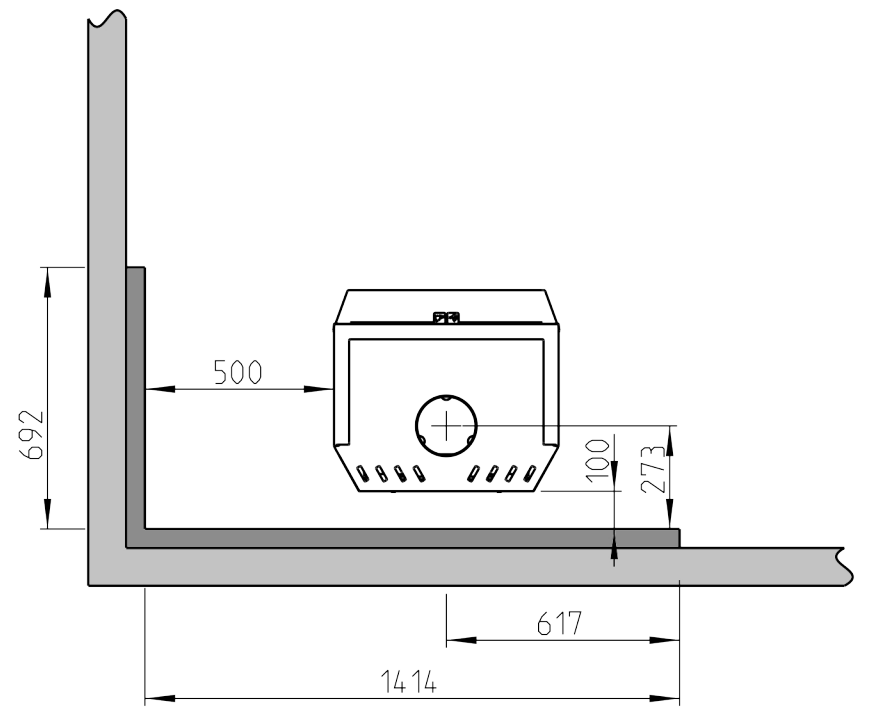
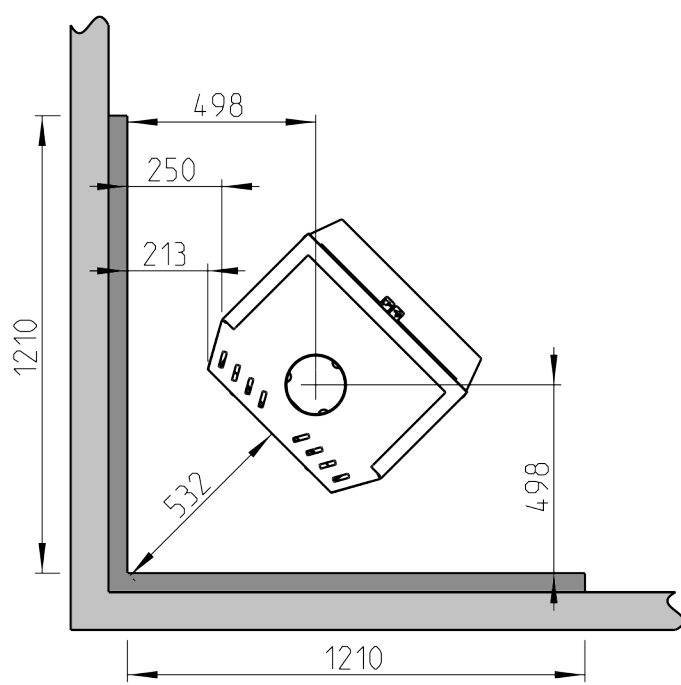
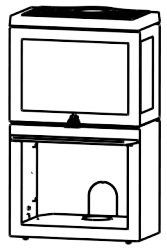
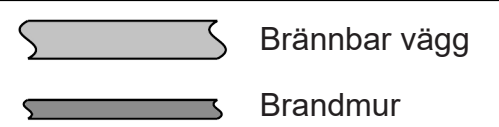

Med eftermonterad gjutjärnssida

